

IOWA DEPARTMENT OF NATURAL RESOURCES  
LAND & WATERS BUREAU  
WALLACE STATE OFFICE BUILDING

ADDENDUM No. 3

HICKORY GROVE LAKE  
MECHANICAL DREDGING & SHORELINE ARMORING  
STORY COUNTY, IOWA  
PROJECT NUMBER: 16-02-85-05

November 9, 2018

*This Addendum is issued to modify, explain or correct the original Drawings and Specifications, and is hereby made a part of the Contract Documents. Please attach this Addendum to the Project Manual in your possession. Insert the number and issue date of this Addendum in the blank space provided on the Proposal Form.*

**Specifications:**

- A. 00120 - SPECIAL NOTICE TO CONTRACTORS - The cost estimate for the project has been revised to \$3,700,000.00.
- B. 00300 - PROPOSAL - Because of the increase in the estimated cost, the Proposal Guarantee amount and the Liquidated Damages amount have been increased to \$200,000.00 and \$1,000/day, respectively. The proposal has been updated to reflect these changes.
- B. 00500 - CONTRACT - Because of the increase in the estimated cost, the Proposal Guarantee amount and the Liquidated Damages amount have been increased to \$200,000.00 and \$1,000/day, respectively. The contract has been updated to reflect these changes.

**Plans:**

- A. Cast-in-place bridge abutments meeting the attached design are an approved substitution to bid item #34, *Precast Concrete Bridge Abutment System*. Concrete mix shall be C-4.

**Substitutions:**

- A. The Steel Pratt Truss Bridge as manufactured by Wheeler, of Bloomington, Minnesota is considered an allowable substitutions for bid item #32, if cast in place bridge abutments are used.

Time and Date of Letting **11:00 AM, November 15, 2018**

**PROPOSAL**

Project Description and Location

Project No. **16-02-85-05**

**MECHANICAL DREDGING & SHORELINE ARMORING  
HICKORY GROVE LAKE  
STORY COUNTY, Iowa**

Proposal of: \_\_\_\_\_  
(Name of Bidder)

Located at: \_\_\_\_\_  
(Address) (Telephone include area code)

Amount of Proposal Guarantee	Specified completion date or Number of Working Days	Approx. or Specified Starting Date or Number of Working Days	Liquidated Damages Per Day
\$200,000.00	4/30/2020	2/1/2019	\$1,000.00

The undersigned hereby agrees, if awarded the contract, to execute the proposed contract and to furnish an approved performance bond in a amount not less than 100 percent of the contract award within 30 days after the date of approval of award of the contract, and to provide all labor, materials, and equipment required to complete the project designated above, for the price hereinafter set forth, in strict compliance with the contract documents prepared by the Iowa Department of Natural Resources.

The undersigned agrees, if awarded the contract, to commence the work within a reasonable time after the preconstruction conference or by the specific starting date, if so specified, and to complete the work within the contract period, or to pay liquidated damages in the amount stipulated herein for each calendar day the work remains uncompleted after the expiration of the contract period or any authorized reduction thereof.

A proposal guarantee in the amount stipulated herein is included with this proposal, to be forfeited to the Iowa Department of Natural Resources if the undersigned fails to execute the contract and furnish an approved performance bond, if awarded the contract.

By virtue of statutory authority, preference will be given to products and provisions grown and coal produced within the state of Iowa, and also, a resident bidder shall be allowed a preference against a nonresident bidder from a state or foreign country which gives or requires a preference to bidders from that state or foreign country on projects in which there are no federal funds involved.

BY

\_\_\_\_\_  
(Iowa Contractor Registration No.) (Signed) (Date)

\_\_\_\_\_  
(FID/EIN/SSN) (Phone Number) (Fax Number)

\_\_\_\_\_  
(Email Address)

By signing and submitting the proposal, the bidder:

1. Gives an unsworn declaration on behalf of each person, firm, association, partnership, or corporation has not, either directly or indirectly, entered into any agreement, participated in any collusion, or otherwise taken any action in restraint of free competitive bidding in connection with such contract, and is not under debarment currently by the Federal government for a criminal violation which is reasonably related to bidding and contracting procedures; and

2. Affirms to have examined the plans, specifications, and job site to become acquainted with the adjacent areas, means of approach to the site, conditions of the actual job site, and the facilities for delivering, storing, placing, and handling of materials and equipment.

**SCHEDULE OF PRICES**

Project Description and Location

**MECHANICAL DREDGING & SHORELINE ARMORING, HICKORY GROVE LAKE, STORY COUNTY**

Name of Bidder

**THE "UNIT PRICE" AND "AMOUNT" COLUMNS MUST BE FILLED IN FOR THIS PROPOSAL TO BE CONSIDERED COMPLETE. IF THERE IS A DISCREPANCY BETWEEN UNIT BID PRICES, EXTENSIONS, OR TOTAL AMOUNTS OF BID, THE UNIT PRICES SHALL GOVERN.**

Item No.	Description	Estimated Quantity	Unit Price	Amount
1	24" Dia CMP	418 Lin. Ft.		
2	3/8" Minus Crushed Stone	6 Tons		
3	30" Dia. CMP	45 Lin. Ft.		
4	36" Dia. CMP	76 Lin. Ft.		
5	5" PCC	84 SY		
6	6" PCC	4530 SY		
7	8" Dia. CMP	53 Lin. Ft.		
8	942 Draw Down	2 Each		
9	Class 10 Excavation (Embankment)	73,279 CY		
10	Class 10 Excavation (Waste)	22,586 CY		
11	Class A Crushed Stone	84 Tons		
12	Class D Revetment	266 Tons		
13	Class D Revetment - Linear Mounds - Labor Only	1300 Tons		
14	Class D Revetment - Salvaged Rock - Labor Only	660 Tons		
15	Class E Revetment	13,688.6 Tons		
16	Clearing and Grubbing	3.38 Acres		
17	Compaction with Moisture and Density Control	29,109 CY		
18	Concrete Testing	1 Lump Sum		

19	Construction Staking	1	Lump Sum		
20	Dewatering	1	Lump Sum		
21	Dock Abutment	4	Each		
22	Engineering Fabric	1,900	SY		
23	Flexamat	962	Lin. Ft.		
24	Handicap Signs	5	Each		
25	In-Lake Access	1	Lump Sum		
26	M&D Testing	1	Lump Sum		
27	Mobilization	1	Lump Sum		
28	Mulch Sock	7,116	Lin. Ft.		
29	Parking Bumpers	10	Each		
30	Pavement Removal	1,946	SY		
31	Pavement Striping	1,584	Lin. Ft.		
32	Pedestrian Trail Bridge - 10' x 100'	1	Each		
33	Porous Backfill - Pea Gravel - Labor Only	240	Tons		
34	Precast Concrete Bridge Abutment System	2	Each		
35	Seeding - Native Grass	12	Acres		
36	Seeding - Stabilizing Crop	13.8	Acres		
37	Service Vehicle Sign	1	Each		
38	Site Restoration	1	Lump Sum		
39	Special Backfill	1,796	Tons		
40	Structural Concrete	788	SY		
41	Swale w/ Intake and Tile	1	Lump Sum		
42	Traffic Control	1	Lump Sum		
43	Woody Debris Removal	1	Lump Sum		
		<b>Base Bid</b>	<b>Subtotal</b>		

	Alternate 1			
44	Class 10 Excavation (Waste)	42,382	CY	
		<b>Alternate 1</b>	<b>Subtotal</b>	
	Alternate 2			
45	Class 10 Excavation (Waste)	11,215	CY	
		<b>Alternate 2</b>	<b>Subtotal</b>	
	Alternate 3			
46	Class A Crushed Stone	362	Tons	
47	24" Dia CMP	40	Lin. Ft.	
48	Class D Revetment	15	Tons	
49	Engineering Fabric	25	SY	
50	Canoe Access	1	Lump Sum	
		<b>Alternate 3</b>	<b>Subtotal</b>	
<b>Base + Alternate 1 + Alternate 2 + Alternate 3 Total</b>				

Bidder Acknowledges Receipt of Any Issued Addenda Below (Number and Date)	List of Subcontractors (Attach additional pages, if necessary)
Addendum #1 – 10/31/2018	
Addendum #2 – 11/6/2018	
Addendum #3 – 11/9/2018	

**HICKORY GROVE LAKE  
MECHANICAL DREDGING & SHORELINE ARMORING  
PROJECT NO. 16-02-85-05  
STORY COUNTY, IOWA**

**THIS AGREEMENT**, made this \_\_\_\_\_ day of \_\_\_\_\_, 20\_\_\_\_ by and between the state of Iowa acting through the Department of Natural Resources hereinafter called the **DEPARTMENT** and: \_\_\_\_\_ **located at** \_\_\_\_\_ hereinafter called the **CONTRACTOR**

**WITNESSETH:** That the **DEPARTMENT** agrees to pay the **CONTRACTOR** the contract price provided herein for the fulfillment of the work and the performance of the covenants set forth herein, and the **CONTRACTOR** agrees with the **DEPARTMENT** to commence and complete the project described as follows:  
This project consists of mechanically dredging portions of the lake, placing fish habitat, constructing two boat ramps, and armoring the shoreline.

For the Sum of: \_\_\_\_\_ **Dollars (\$)** \_\_\_\_\_ and all extra work in connection therewith, all in accordance with the terms and conditions herein contained: and to furnish at the **CONTRACTOR'S** own proper cost and expense, all material, equipment, labor, insurance, and other accessories and services necessary to construct and complete, in a workmanlike manner, ready for continuous operation, the above mentioned project. The work shall be performed in accordance with the requirements and provisions of the following documents, all of which are made a part hereof and collectively evidence and constitute the contract:

1. Notice to Bidders.
2. Instructions to bidders.
3. DNR Standard Specifications and Current Supplemental Specifications
4. Project Specifications Including Addenda Number \_\_\_\_\_ Through \_\_\_\_\_
5. Drawings, Sheet Number     A.01     Through     T.01     Inclusive
6. Contractor's Proposal.
7. Proposal Guarantee Bond.
8. Performance Bond.
9. This Instrument.
10. Modifications or Change Orders pursuant to DNR Standard Specifications
11. Resident Bidder Preference Certification on Non-Federal-Aid Projects

The parties to this contract understand that time of completion of the work under this contract is the essence to the contract. The **CONTRACTOR** hereby agrees to commence work under this contract in accordance with Section 1108 of the DNR Standard

Specifications and to complete all the work by     April 30, 2020    

The **CONTRACTOR** hereby agrees that liquidated damages in the amount of     One Thousand     Dollars \$     1,00.00     shall be retained or assessed against the **CONTRACTOR** for each day and every day the completion of the work is delayed beyond the time specified herein, not as a penalty, but as a mutually agreed to, predetermined amount to

reimburse the **DEPARTMENT** for salaries of engineers and reviewers, clerk hire, interest charged during the period for delays and loss of use.

It is understood that the **CONTRACTOR** consents to the jurisdiction of the courts of Iowa, to hear, determine and render judgment as to any controversy arising hereunder, and that this contract shall be governed by, and construed according to, the laws of the state of Iowa.

**IN WITNESS WHEREOF**, the parties hereto have executed this Agreement, in the day and year first above mentioned.

**FOR THE DEPARTMENT:**

**FOR THE CONTRACTOR:**

\_\_\_\_\_  
Director

\_\_\_\_\_  
(Signature and Title)

This contract was approved by the **NATURAL  
RESOURCES COMMISSION** at its meeting held on

\_\_\_\_\_  
(Firm)

\_\_\_\_\_  
(Date)

\_\_\_\_\_  
(Address and Zip Code)

Seal if by a Corporation:

Identification Number \_\_\_\_\_

Soc. Sec. No. \_\_\_\_\_

Or Fed. I. D. No. \_\_\_\_\_

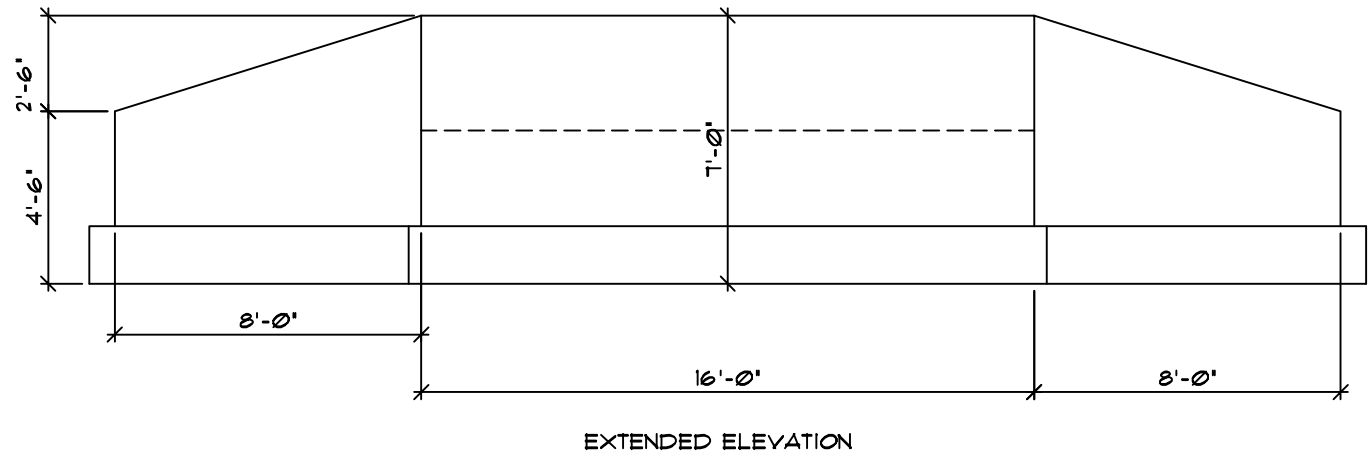
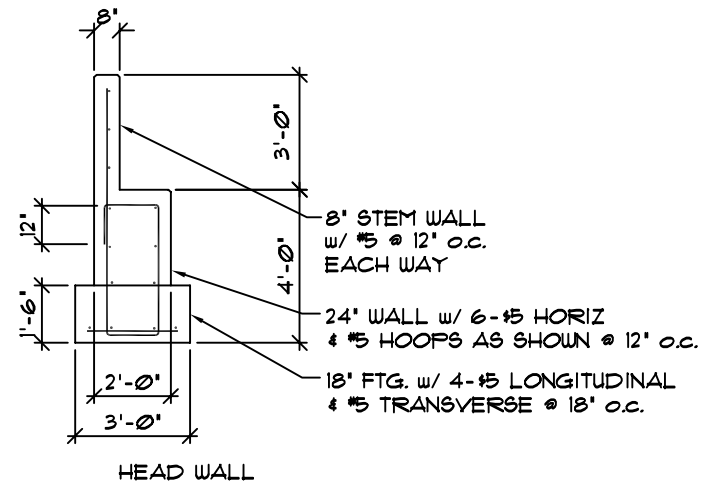
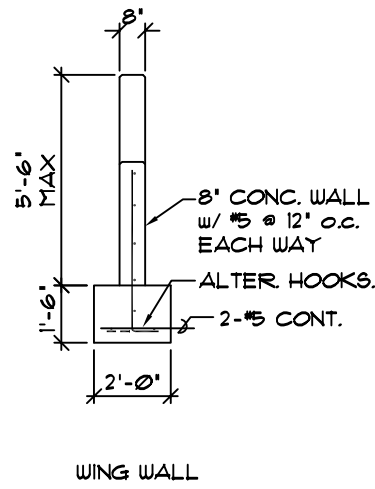
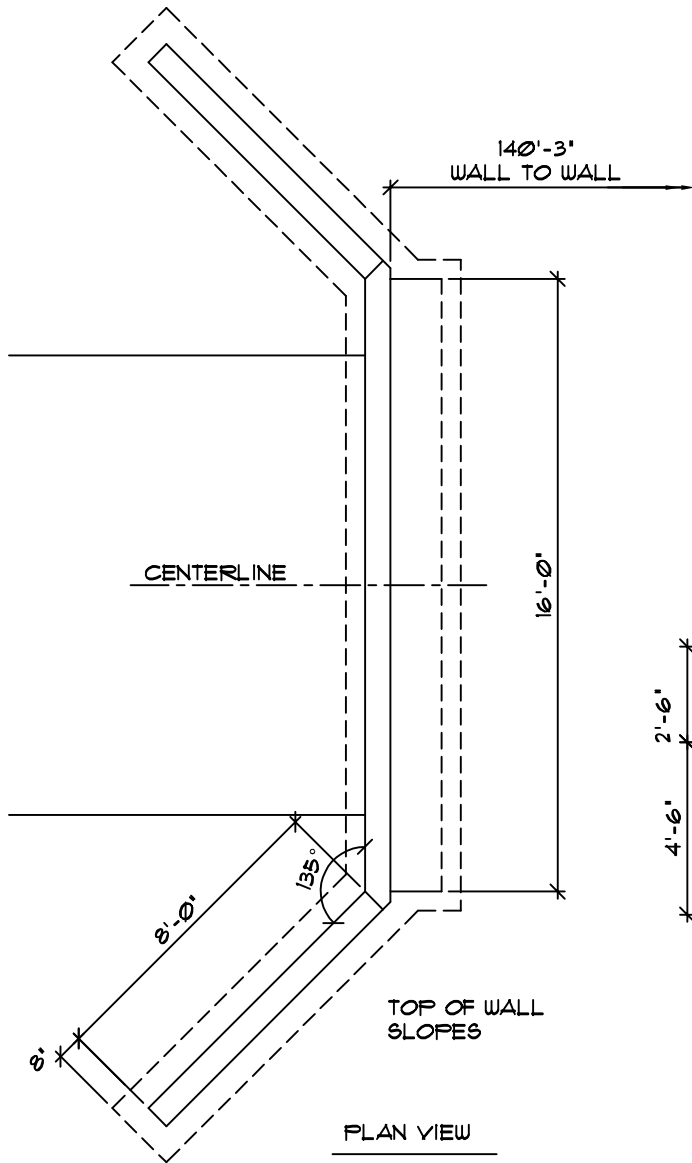

BRIDGE ABUTMENT DETAILS